

Robust-Aire Owner's Manual



800 Deere Rd. Prescott, WI 54021 • 715-262-4488 • sales@kascomarine.com • kascomarine.com

PN: 772155 Rev 6/2020

TABLE OF CONTENTS

Safety Precautions.....	Page 2
Diffuser Installation.....	Page 3
Compressor Connections.....	Page 4
No Cabinet (NC) System Installation.....	Page 6
Base Mount Cabinet Installation.....	Page 7
Post Mount Cabinet Installation.....	Page 8
Remote Manifold Installation.....	Page 9
Startup Procedure.....	Page 11
Winter Warning.....	Page 11
Maintenance.....	Page 11
Troubleshooting.....	Page 12
Warranty.....	Page 13

Safety Precautions

- Caution should be used when dealing with any electrical equipment.
- Caution should be used around water.
- Running the system in below freezing conditions may create open areas of water at the diffuser locations and thin ice in the surrounding area.
- System owner will assume all risks with operating the Robust-Aire System during winter months. Some areas require warning signs to be posted, check your local laws and ordinances.
- Do not use boats that tip easily for installation, such as a canoe, and follow all boating safety rules and regulations, including wearing a PFD. (Personal Flotation Device)
- Consult a qualified electrician for electrical installation.

Diffuser Installation

The effectiveness of the Robust-Aire® Diffuser is dependent on where the diffusers are placed in the pond. Place the Robust-Aire® Diffusers equally from each other at a depth that represents most of the pond. Please contact Kasco with any questions on placement or system operation.

CAUTION: Do not use boats that tip easily for installation (i.e. a canoe). Wearing a personal floatation device is recommended.

1. It is recommended to use a buoy for each diffuser to mark the area that it is placed.
2. Unroll the SureSink™ Aeration Tubing on shore to remove any twists or knots. Performance will decrease if the tube is not properly uncoiled.
3. Each tubing length is 100 feet. If more than 1 length of tubing is required to reach diffuser location, connect any additional tubes according to the SureSink™ Tube instructions. Unroll these tubes as you did with the first tube. Multiple rolls of tubes can be loaded into a boat and connected as needed while making your way to the proposed diffuser location. You can also connect any number of 100' lengths together and have someone assist in feeding it from shore. The excess tubing can then be cut off at shore before connecting to the compressor.
4. Drop loose end of the tubing near the compressor cabinet. Allow a few extra feet of tubing to work with so the tube will reach the cabinet after trenching between the shore and the compressor.
5. Drive the boat in reverse to avoid damaging the boat prop and slowly make your way to the marking buoy placing the tubing as you go.
6. Once you reach the marked buoy, thread a rope through the two holes of the diffuser base. Pull through until the rope is at the midway point by the diffuser base.

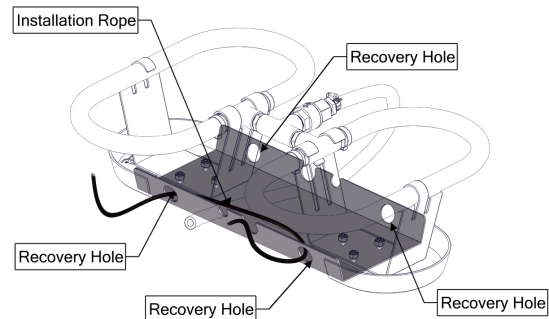
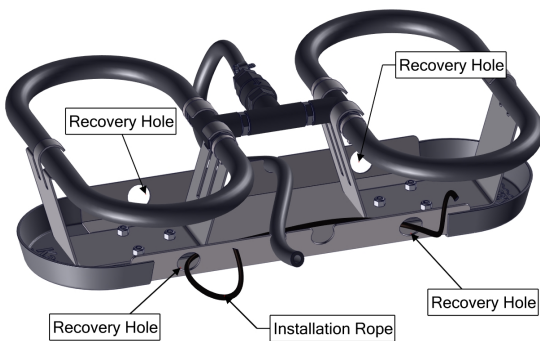

7. While holding the two ends of the rope, gently lower the diffuser assembly into the water.
8. Continue lowering the assembly slowly until it reaches the bottom of the pond.
9. The Robust-Aire® Diffuser should now be seated properly on the bottom of the pond. Remove rope by pulling on one end (*Optional: For ease of future maintenance, it is recommended to leave rope looped through diffuser base and tie both ends to marker-buoy or duck decoy. This will allow diffusers to be located easily and pulled up for maintenance.*)
10. Repeat the process for additional Robust-Aire® Diffuser locations.

Compressor Connections

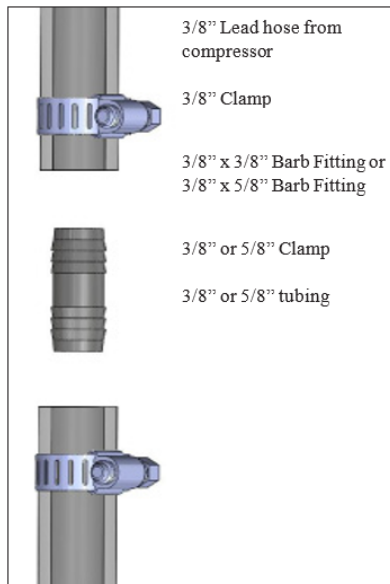

Do not over tighten clamps!

1. Finish connecting the tubing to the lead hose from the compressor with the supplied barb fitting. Tighten clamps to both supply tubing and compressor hose.
2. Bury tubing from the shore to the compressor.

No Cabinet Systems:

Parts included in RA(H)1-NC Systems:

- (1) Robust-Aire Diffuser Assembly
- (1) 3/8" x 100' SureSink Tubing w/fitting kit
- (1) Single Head Compressor
- (2) 1/4" NPT x 3/8" barb brass elbow
- (4) Compressor Vibration Isolation Feet
- (4) 1/4" Flat Washer
- (4) 1/4" Lock Nut
- (1) Cooling fan assembly (either 115V with plug or 230V without plug)
- (4) #10 x 3/4" bolt
- (4) #10 split washer
- (4) #10 Nut
- (1) 3' length of 3/8" hose
- (3) Hose Clamp
- (1) Intake Hose
- (1) Intake Block
- (1) Filter Minder
- (1) Air Filter

Parts included in RA(H)2-NC Systems:

- (2) Robust-Aire Diffuser Assembly
- (2) 3/8" x 100' SureSink Tubing w/fitting kit
- (1) Single Head Compressor
- (3) 1/4" NPT x 3/8" barb brass elbow
- (4) Compressor Vibration Isolation Feet
- (4) 1/4" Flat Washer
- (4) 1/4" Lock Nut
- (1) Cooling fan assembly (either 115V with plug or 230V without plug)
- (4) #10 x 3/4" bolt
- (4) #10 split washer
- (4) #10 Nut
- (3) Hose clamp
- (1) Intake Hose
- (1) Intake Block
- (1) Filter Minder
- (1) Air Filter
- (1) Two Station Manifold Assembly
- (2) Manifold Mounting Screw

Parts included in RA(H)3-NC Systems:

- (3) Robust-Aire Diffuser Assembly
- (3) 3/8" x 100' SureSink Tubing w/fitting kit
- (1) Double Head Compressor

-
- | | |
|---|---|
| (3) 1/4" NPT x 3/8" barb brass elbow | (4 - 6) Robust-Aire Diffuser Assembly |
| (4) Compressor Vibration Isolation Feet | (4 - 6) 3/8" x 100' SureSink Tubing w/fitting kit |
| (4) 1/4" Flat Washer | (2) Double Head Compressor |
| (4) 1/4" Lock Nut | (4) 1/4" NPT x 3/8" barb brass elbow |
| (1) Cooling fan assembly (either 115V with plug or 230V without plug) | (8) Compressor Vibration Isolation Feet |
| (4) #10 x 3/4" bolt | (8) 1/4" Flat Washer |
| (4) #10 split washer | (8) 1/4" Lock Nut |
| (4) #10 Nut | (2) Cooling fan assembly (either 115V with plug or 230V without plug) |
| (3) Hose clamp | (8) #10 x 3/4" bolt |
| (1) Intake Hose | (8) #10 split washer |
| (1) Intake Block | (8) #10 Nut |
| (1) Filter Minder | (6) Hose clamp |
| (1) Air Filter | (1) Intake Hose |
| (1) Three Station Manifold Assembly | (1) Intake Block |
| (2) Manifold Mounting Screw | (1) Filter Minder |
| | (1) Air Filter |
| | (2) Two or Three Station Manifold Assembly |
| | (4) Manifold Mounting Screw |

Parts included in RA(H)4-NC, RA(H)5-NC and RA(H)6-NC Systems:

Installation Tools & Materials:

- Phillips Screwdriver
- Flathead Screwdriver
- 5/16" socket or nut driver
- 1/4" socket or nut driver
- 9/32" socket or nut driver
- 3/8" socket or nut driver (#10 nuts)
- 7/16" socket or nut driver (1/4" nuts)
- Thread sealant (Teflon tape)

No Cabinet Installation:

Make sure you have met the following installation conditions and clearances:

- Compressor needs to be installed in a clean, dry location.
- Compressor needs to be protected from dirt and moisture and from the outdoor environment such as rain, snow, flooding, etc.
- Ambient air temperature must not exceed 104° F (40°C).
- Adequate ventilation and cooling air (air flow across the compressor) must be provided to keep the compressor from overheating and causing damage. The included fan has been provided for this purpose.
- Included is a simple bracket to allow easy mounting to a wall, floor or bench.

After the proper location has been determined, use the following diagrams to complete the installation:

120V compressors are supplied with a NEMA 5-15 plug. 240V compressors are supplied with flying leads. The leads can be hard-wired into 240V service or an appropriate plug can be installed.

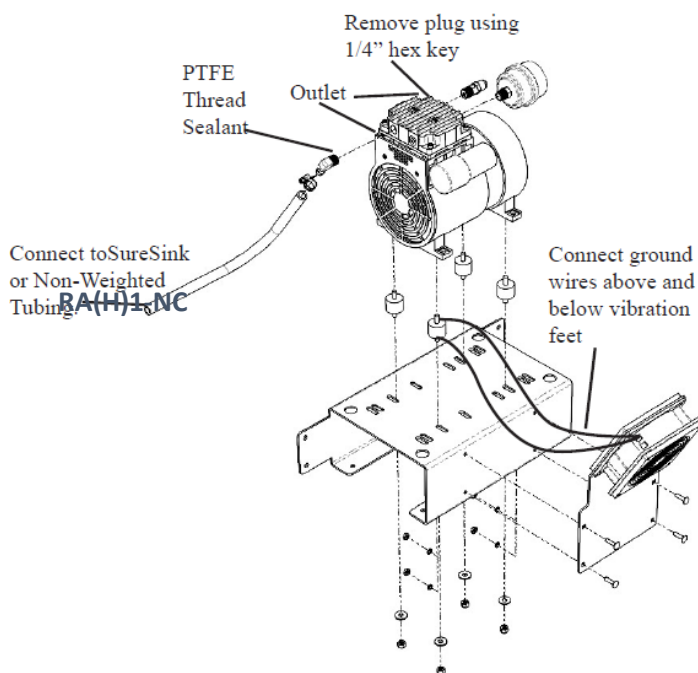

Kasco recommends that the site service providing system power have a human-rated Ground Fault Circuit Interrupter outlet (120V) or human-rated Ground Fault breaker (240V) for your protection. Contact a licensed electrician to install 120 or 240 volts (depending on model), single phase power at the compressor location with appropriate human-rated ground fault protection.

Base Mount Cabinet Installation:

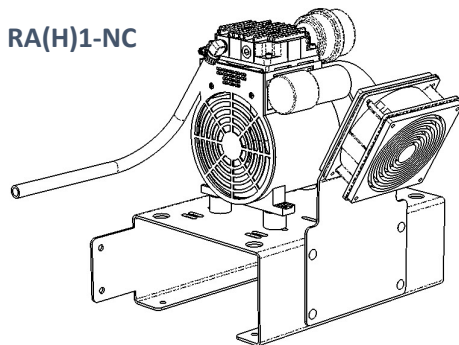

RA(H)3-NC

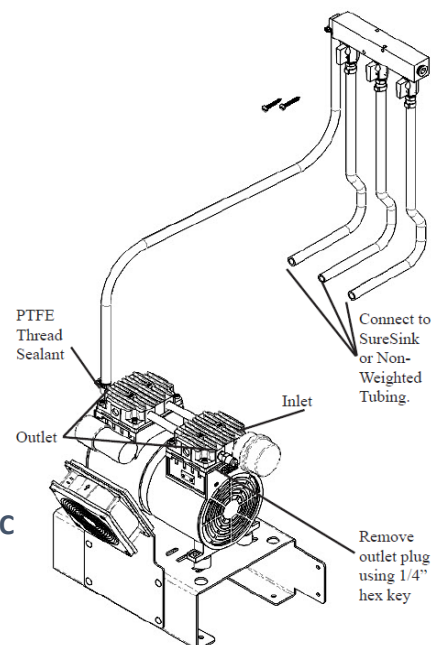

Choose a location placed far enough from shore to avoid the potential of flooding. Plantings can be used to help hide the cabinet from sight, however, be sure that both the inlet and outlet vents will not be blocked as air flow is required to keep the compressor from over-heating.

The assembly can be placed directly on the ground or attached to a concrete pad. The bottom flanges have holes which can be used to anchor the cabinet.

The cabinet should be placed adjacent to the electrical service which will power the system. The cabinet has 6-foot power cord(s) with plugs. **DO NOT USE EXTENSION CORDS.**

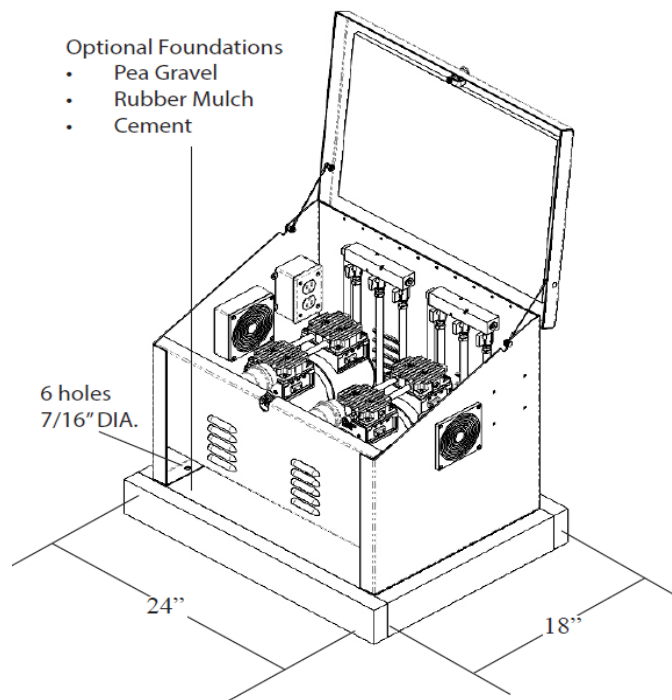

Post Mount Cabinet Installation:

The post mount cabinet can be attached to a post or to a vertical wall (shed) with electrical service. (2) lag screws are provided to mount the post mount cabinet. Drill (2) 3/16" holes vertically spaced 2 3/8" apart. Install (1) lag screw into the wall or post, leaving the hex head out about 1/4" using a standard 7/16" socket wrench. Hang the cabinet from this screw using the bottom key-hole slot in the cabinet (a second person may be needed to help hold the cabinet). Install the second lag screw in the top mounting hole. Tighten both lag screws.

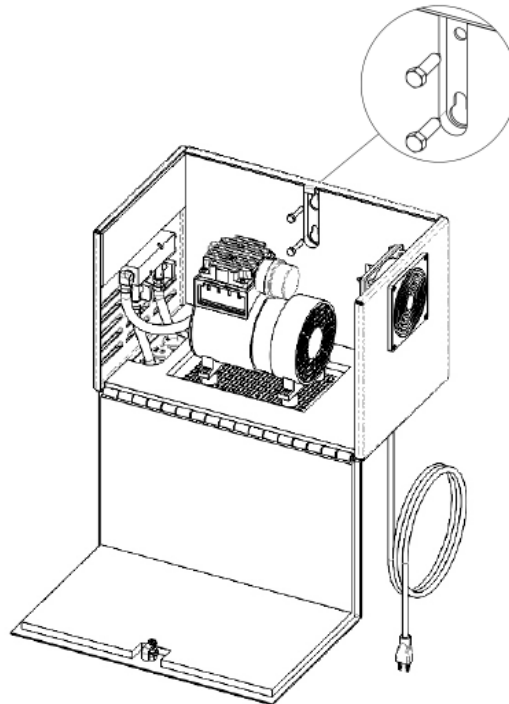

Remote Manifold Installation

Robust-Aire systems that were ordered with the optional remote manifold were pre-built with a single air-line exiting each compressor. Follow the instructions below to assemble and install the remote manifolds.

Installation Tools & Materials:

- 3/4" Sch. 40 PVC Pipe (amount to be determined by user)
- 3/4" Sch. 40 PVC Pipe Couplings (as needed)
- PVC Primer and Glue
- PVC Pipe Cutter
- Shovel or other trenching tools
- Pliers (hose clamp installation)
- Thread sealant

A trench will need to be excavated to bury the PVC air-line. Start by determining the path of the trench from the Robust-Aire system to an area by shore. The path should be as straight as possible with a gentle downward slope from the Robust-Aire system towards the shore. Dig the trench 6" to 8" deep.

For two or three station valve manifolds, excavate an area large enough to bury the included valve box. An area at least 18" wide by 25" long x 13" deep will be needed. Dig the area deeper and add crushed rock to allow for needed drainage.

CAUTION: In northern climates where the ground freezes during the winter, be sure there are no high or low spots in the PVC air-line. Condensation in the air line may pool, freeze, and block the flow of air to your diffuser. This can also damage your compressor.

For RA1 – RA3 systems, a single trench is required.

For RA4 – RA6 systems, either a single trench or two separate trenches may be required depending on pond size and diffuser placement locations.

Connect brass barb fitting to PVC adapter, applying thread sealant to male threads on PVC adapter. Connect barb fitting to rubber compressor hose lead and secure with clamp.

Connect PVC adapter and PVC pipe with primer and glue. Add pipe sections as needed to reach the remote manifold.

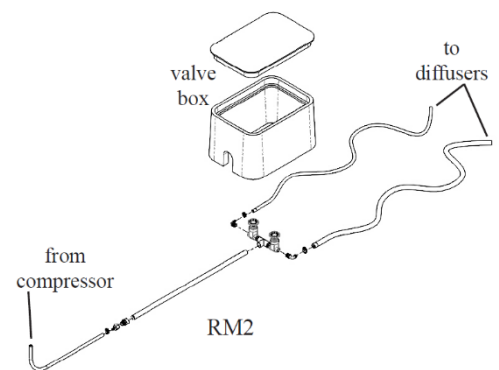
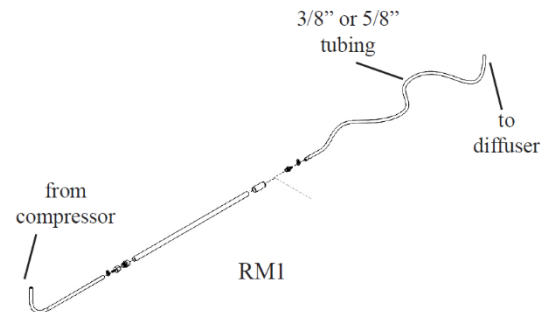

Prime and glue supplied manifold assembly to the PVC compressor supply pipe. Install 3/8" or 5/8" barb fittings depending on size of SureSink™ tubing being run to each diffuser. Apply thread sealant to male threads of barb fittings. Attach tubing to each barb fitting and secure with hose clamp.

When applicable, place valve box over manifold assembly and fill around box and entire length of trench with the excavated dirt. The lid of the valve box should be flush with the surrounding ground surface. When system has been completely installed, use the valves (multiple diffuser systems) to balance flow to each diffuser.

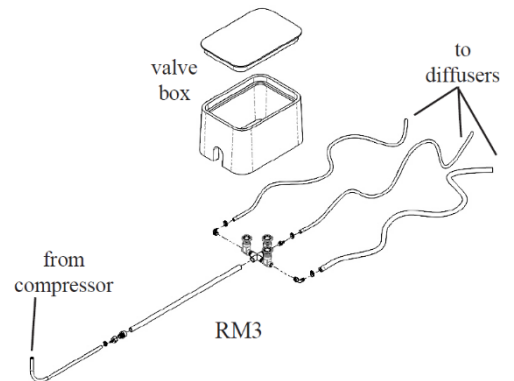

Startup Procedure:

Important Installation Warning

Thermal stratification refers to layering that occurs in some lakes and ponds allowing warmer water to sit on the top of colder denser water on the lake bottom.

If you install your unit into a body of water that is extremely stratified, caution is needed when starting the system. In some cases, the colder water sitting on the bottom could hold gases that can be harmful to fish. Also, the colder bottom water often has little or no dissolved oxygen present.

A simple test for thermal stratification is to place a thermometer into the body of water and gradually check for temperature change from top to bottom of the lake or pond. Measuring temperature every two feet of depth is adequate. Keep the thermometer at each depth long enough for a temperature to accurately be taken, followed by quickly bringing the thermometer to the surface to record each temperature.

If the colder water (anything 4°F colder than surface) represents more than 30% of the overall volume, it is advisable to start aeration at a slower pace by running the system only for short time intervals. Suggested start up intervals for a stratified lake could be running for 1 hour per day for one week; gradually increasing until running continuously. Lakes and ponds react differently to diffused aeration so exact timeframes can be difficult to predict. Sunny days are preferable to cloudy days for system start-up as photosynthesis will supplement oxygen levels as the water is mixed.

If you have questions about this procedure, please contact your distributor or e-mail Kasco Customer Service at sales@kascomarine.com

Winter Operation

System owner assumes all risks with operating the Robust-Aire System during winter months.

Operating the Robust-Aire® system during the winter or freezing temperatures may create open areas of water at the diffuser locations. Also, ice will be thin surrounding those areas. Extreme caution should be used to avoid injury or fatality from falling into the water. Signs to indicate the danger to others are recommended. Check your local laws and ordinances as some areas require warning signs to be posted.

In climates where temperatures fall below freezing, it is recommended that you insulate the air lines from the compressor cabinet a minimum of 3 feet into the water, at low water level. Using closed cell polyurethane foam to insulate will prevent ice buildup in the lines. Ice buildup can block the flow of air to your diffuser and can cause damage to your compressor. Insulation should pass through the ice, into open water below.

Moving the diffusers closer to shore in winter will allow a small area of the shoreline to remain open, preventing winter kill.

Maintenance

Warning! Product surfaces become very hot during operation. Allow compressor to cool before servicing. Disconnect electrical power before performing maintenance.

Check filter monthly; clean or replace intake filter when filter minder shows a red band. Reset by pushing the small button on the minder top.



Failure to maintain clean air filter will lead to excessive heat and premature failure of the compressor.

- Replacement Air Filter Element part number 771018

Troubleshooting

“Compressor and fan are not running.”

Ensure the power cord is connected. Check if the user supplied GFCI circuit is tripped. Reset as necessary

“The fan is running but the compressor is not”

Inspect the compressor and capacitor wiring and connections.

“The compressor and fan are running, but there are no bubbles coming out of any diffusers”

Check for leaks in line connections and at the compressor. Check connections for tightness.

“The compressor and fan are running. There are bubbles coming out of some diffusers, but not all of them.”

The valves in the cabinet may need to be balanced. There may be a clogged diffuser that needs to be cleared. The compressor may be due for a rebuild.

“The compressor stops and restarts”

Ensure the fan is working properly. Capacitor may need replacement.

Please contact Kasco or your distributor if problems persist.

Warranty

Diffuser Assembly: 5 years

Teich-Aire compressor: 2 years

Exterior Cabinet: 5 years

SureSink Tubing: 10 years

Kasco® Marine, Inc. warrants this Robust-Aire® System to be free from defects in material or workmanship under normal use and service. The Kasco Marine, Inc. obligation under this warranty is limited to replacing or repairing free of charge any defective part within the warranty period. Customer shall pay shipping charges for returning the unit to Kasco or an Authorized Repair Center.

THIS WARRANTY IS IN LIEU OF ANY OTHER WARRANTIES, EXPRESSED OR IMPLIED, AND ANY OTHER OBLIGATION OR LIABILITY WHATEVER ON THE PART OF KASCO MARINE, INC. AND IN NO EVENT SHALL KASCO MARINE, INC. BE LIABLE FOR ANY SPECIAL OR CONSEQUENTIAL DAMAGES.

Warranty is void if:

- The System is not maintained properly according to the Maintenance Recommendations supplied in this Owner's Manual.
- The System is damaged by unauthorized tampering.

Warranty Claim Procedure:

The best method for establishing warranty period is by the original receipt. Register your system online at: www.kascomarine.com.

Once the warranty coverage has been established, the unit may be sent to a Kasco Authorized Repair Center for evaluation and repair. Please contact Kasco Marine prior to shipping to receive any updated information and/or repair form.

Shipping Address:

Kasco Marine, Inc.
800 Deere Rd.
Prescott, WI 54021
Attn: Repairs

Call or email Kasco Marine to locate your nearest Authorized Repair Center.

715-262-4488
returns@kascomarine.com.

Please include the Repair Form with the shipment. If no Repair Form is available, include: Name, Physical address (for return delivery of the repaired unit), Daytime phone number, and E-mail address for correspondence regarding the warranty claim.

Expedited shipping for the return of the unit is at the customer's expense. Kasco will return units repaired under warranty at our expense via ground freight within the continental United States.

Other Repairs:

Failed equipment can be repaired, often at substantially lower costs than replacement. Please ship according to above instructions. Contact Kasco for updated information and/or repair form.

Kasco Marine does estimates on repairs at the customer's request. This request should be included in the documentation that accompanies the returned unit and must include a daytime phone number and/or e-mail address. We will contact the customer with a total after the unit has been evaluated, but before the work is performed.

All estimates that are rejected for repair will be recycled unless otherwise directed by the customer. If the unit is to be returned, it will be assembled to the condition in which it was received and shipped at the customer's expense.

Billing:

All non-warranty repairs will be returned to the customer and billed C.O.D. unless otherwise directed. Kasco Marine also accepts Visa and MasterCard upon completion of the repair.